



THE ENGLISH SCHOOL
MID PROGRAM ENTRY INTO YEAR 3

MATHEMATICS

SATURDAY 30TH MAY 2020

Time allowed: 2 hours

Instructions to candidates

In the boxes below write your name.

Answer all the questions in the spaces provided.

Without sufficient working, correct answers may be awarded no marks.

Information to candidates

This paper has 25 questions.

There are 16 pages in this question paper.

Full marks may be obtained for answers to all questions.

The total marks for this paper is 120.

The marks for each question is shown in round brackets, e.g. (2)

Calculator may be used.

Advice for candidates

Write your answers neatly and in good English.

Work steadily through the paper.

Do not spend too long on one question.

Show all stages in any calculations.

Materials required for the paper

Calculator, ruler graduated in centimetres and millimetres, protractor, pair of compasses, pen, HB pencil, eraser. Tracing paper may be used.

Surname:

.....

Name:

.....

Total Marks:

.....%

1. 2 kilograms of grapes cost £6.20.
 500 grams of grapes and 3 kilograms of plums cost £11.60.
 Work out the cost of 1 kilogram of plums.

£.....
 (3)

2. (a) State the equation of the straight line with a gradient of 3 passing through the y-axis at the point with coordinates (0, -2).

$y = \dots\dots\dots$
 (2)

- (b) What is the equation of the line that passes through the points (-2, 0) and (2, 8)?

$y = \dots\dots\dots$
 (3)

3. (a) Without using a calculator, evaluate $(3 \times 10^{-4}) \div (6 \times 10^{-7})$.
 Show all your workings and give your answer in standard form.

.....
 (2)

- (b) Here are three numbers written in standard form.
 Arrange these numbers in ascending order.

5.6×10^{-7} 8.6×10^{-9} 5.64×10^{-8}

..... , ,
 (2)

4. In class 2 Red there are 26 pupils.
 3 of them play hockey, 12 play football, 5 play rugby and 6 go swimming.
 If a pupil is selected at random, what is the probability that the pupil will:

- (a) **Not** play rugby.

.....
 (1)

- (b) Play hockey or rugby or swim.

.....
 (1)

- (c) Are the events: “play football” and “not play rugby” mutually exclusive?
 Give a reason for your answer.

.....

 (2)

5. In a sale, the normal price of a hat is reduced by 15%
 The sale price of the hat is £20.40.
 Work out the normal price of the hat.

£
 (3)

6. (a) Make a the subject of $d = g + 2ac$

.....
 (2)

- (b) Factorise fully $9ef - 12f$

.....
 (2)

- (c) Expand and simplify $(x + 2)(x - 5)$

.....
 (2)

- (d) Simplify fully $\frac{n^4 + n^7}{n^5}$

.....
 (2)

(e) Solve $\frac{5y+1}{3y+13} = 2$

.....
(3)

7. Nigel bought 12 boxes of melons. He paid £15 for each box.
 There were 12 melons in each box.
 Nigel sold $\frac{3}{4}$ of the melons for £1.60 each. He sold all the other melons at a reduced price.
 He made an overall profit of 15%
 Work out how much Nigel sold each reduced-price melon for.

£
(6)

8. The diagram below shows a solid prism. The cross section of the prism is a trapezium. The prism is made from wood with density 0.7 g/cm^3 . Work out the mass of the prism.

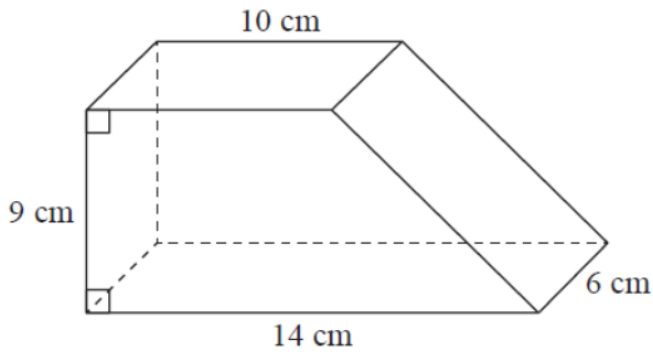

..... g
(4)

9. The diagram shows three identical rectangles.

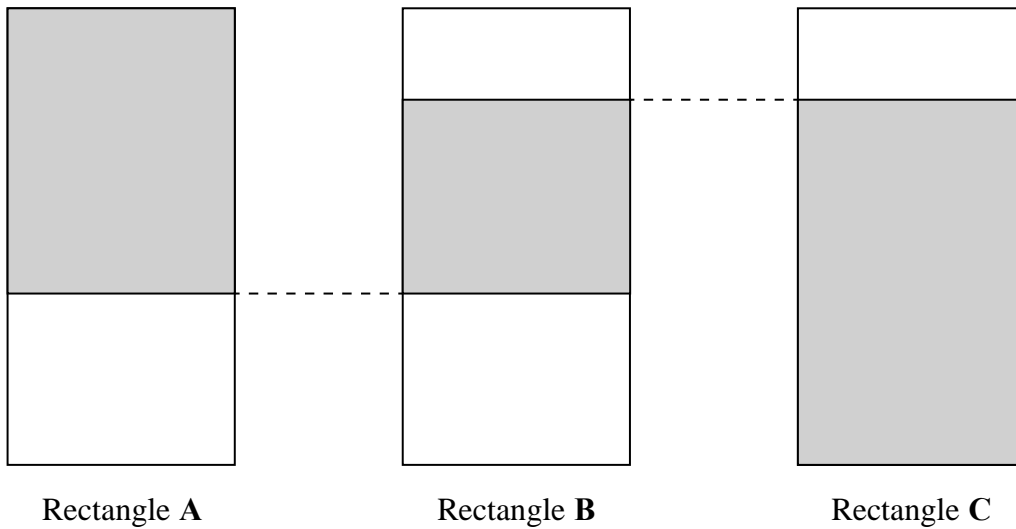

$\frac{5}{8}$ of rectangle **A** is shaded.

80% of rectangle **C** is shaded.

What fraction of rectangle **B** is shaded?

.....
(3)

10. The area of triangle **ABC** is 50 cm^2 .
Find angle f giving your answer correct to 3 significant figures.

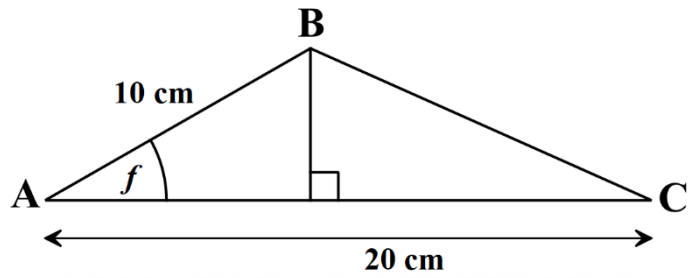

..... °
(4)

11. (a) Wendy travelled on the Eurostar train from St Pancras station to the Gare du Nord station. The Eurostar train travelled a distance of 495 km. The journey time was 2 hours 15 minutes. Work out the average speed of the Eurostar train in kilometres per hour.

..... km/h
(3)

(b) Convert the scale 4 cm to 1 km to a map ratio in its simplest form.

..... :
(2)

(c) A tap is dripping at a rate of 2 litres every 10 minutes. How long will it be, before the tap fills a tank in the shape of a cuboid, with length 8 cm, width 6 cm and height 15 cm? Give your answer in seconds.

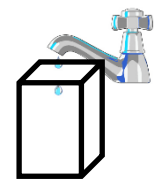

..... seconds
(4)

12. Triangles ABC and ACD are similar.
 Angle $BAC =$ angle CAD
 Angle $ABC =$ angle ACD
 $AB = 5$ cm and $AC = 8$ cm
 Calculate the length of AD

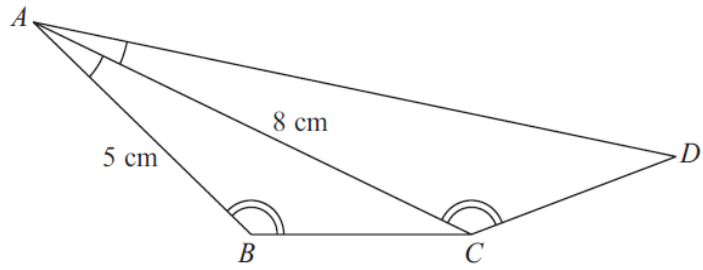

..... cm
 (3)

13. In the grid below shape A' is an enlargement of shape A .

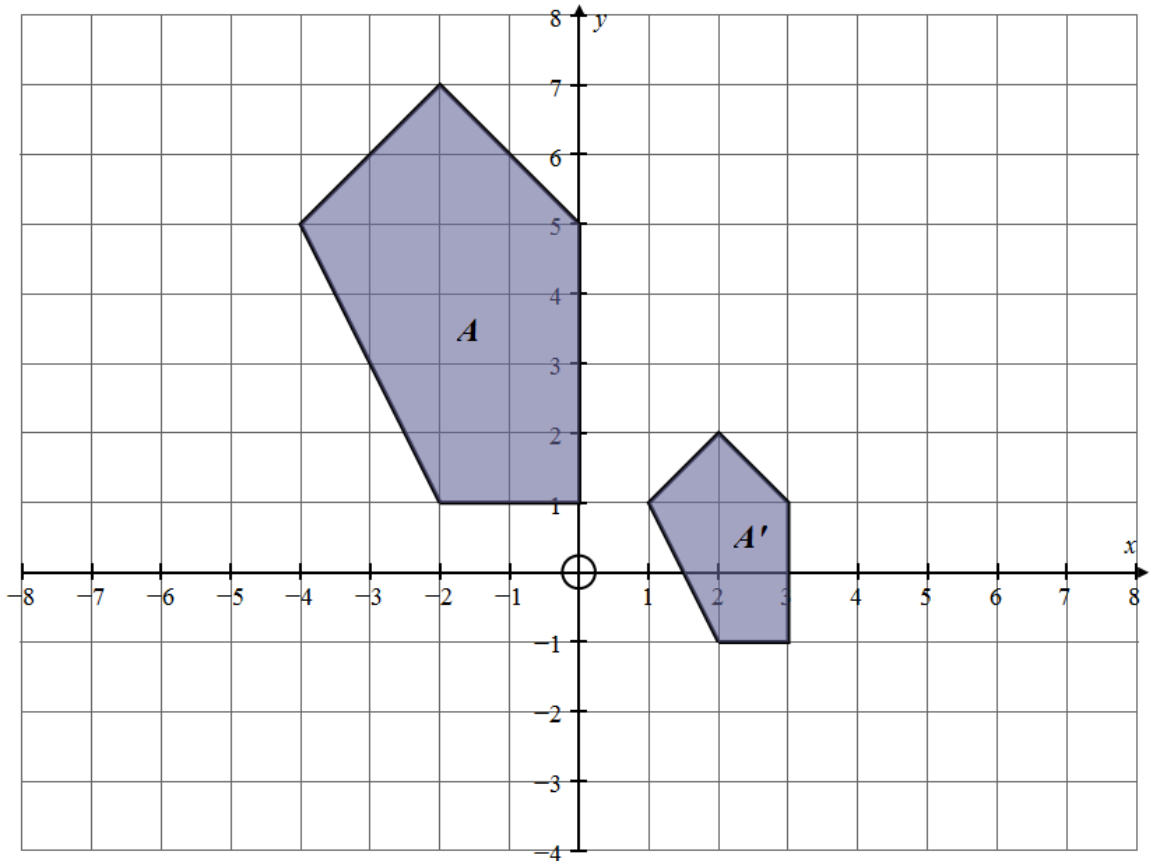

- (a) What is the scale factor of the enlargement?

Scale factor =
 (1)

- (b) Work out the coordinates of the centre of enlargement by drawing rays on the diagram.

(..... ,)
 (2)

14. Match each graph to the correct equation.

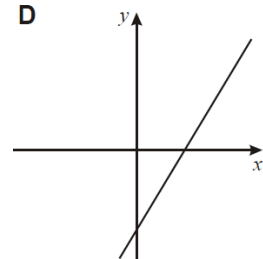
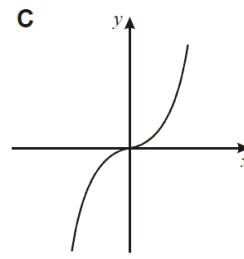
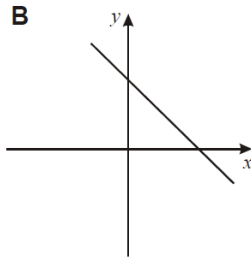
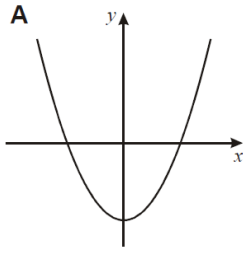

Graph Shows the equation $y = 2x - 6$

Graph Shows the equation $y = x^2 - 4$

Graph Shows the equation $3x + 2y = 12$

(3)

15. In a bag there are only red bricks, blue bricks, green bricks and orange bricks. The number of green bricks in the bag is the same as the number of orange bricks.

Jiao takes at random a brick from the bag.

The table gives the probability that Jiao takes a red brick and the probability that he takes a blue brick.

Colour	red	blue	green	orange
Probability	0.26	0.3		

(a) Work out the probability that Jiao takes an orange brick.

.....
(2)

Jiao puts the brick back into the bag. There are 91 red bricks in the bag. Jiao is going to build a tower using all the red bricks and all the blue bricks but no other bricks. The tower will be in the shape of a cuboid.

There will be 4 bricks in each layer of the tower.

(b) Work out how many layers the tower will have.

.....
(4)

16. (a) $Q = 2u^2 - 5$

Find the value of Q when $u = -3$

$Q = \dots\dots\dots$ (2)

(b) Solve $\frac{3x - 2}{5} - \frac{3 - 4x}{2} = 2$

Show clear algebraic working.

$x = \dots\dots\dots$ (4)

(c) The width of a rectangle is 8 cm less than the length of the rectangle.
The perimeter of the rectangle is 54 cm.

Write down an equation and solve it to find the area of the rectangle.

$\dots\dots\dots \text{cm}^2$ (4)

17. $ABCDEF$ shows part of a regular polygon with interior angle x equal to 156° .

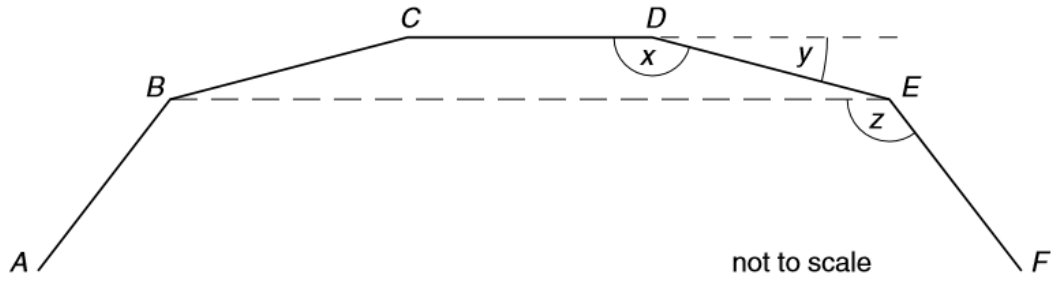

(a) Calculate the size of the exterior angle y .

$y = \dots\dots\dots^\circ$
(2)

(b) How many sides has the regular polygon?

$\dots\dots\dots$ sides
(2)

(c) What is the sum of all the interior angles of the regular polygon?

$\dots\dots\dots^\circ$
(2)

(d) Which type of 4-sided figure is BCDE ?

$\dots\dots\dots$
(1)

(e) Calculate the size of the angle marked z .

$z = \dots\dots\dots^\circ$
(4)

18. Factorise each of the following completely:

(a) $x^2 - 6x - 72$

..... (1)

(b) $x^2 - 225$

..... (1)

19. The diagram shows two similar vases, **A** and **B**.

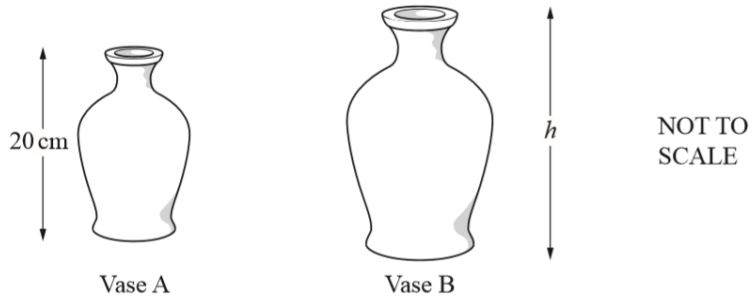

Vase A has height 20 cm and volume 1500 cm^3 .

Vase B has volume 2592 cm^3 .

Calculate h , the height of vase B.

..... cm (3)

20. Hamish buys a new car for \$20 000
 The car depreciates in value by 19% each year.
 Work out the value of the car at the end of 3 years.
 Give your answer to the nearest \$.

\$.....
 (3)

21. The diagram shows two right-angled triangles, DEF and EFG .

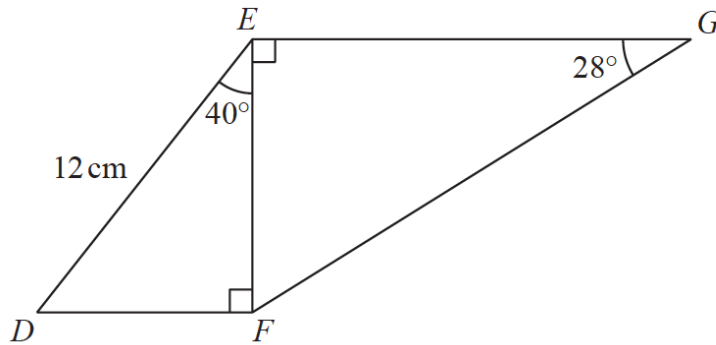
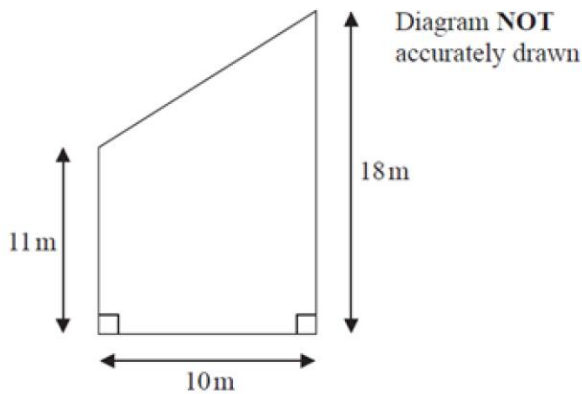

Diagram **NOT** accurately drawn

Work out the length of EG .
 Give your answer correct to 3 significant figures.

..... cm
 (4)

22. Here is part of a field.
 This part of the field is in the shape of a trapezium.
 A farmer wants to put a fence all the way around the edge of this part of the field.
 How much fence will he require? Give your answer correct to 3 significant figures.



..... cm
 (4)

23. A formula describing the driving force, F , in Newtons, of a vehicle is given by

$$F = \frac{P}{v}$$

where P is the power in Watts, and v is the velocity in ms^{-1} .

Given that,

$$P = 145 \text{ Watts to 3 significant figures}$$

$$v = 23.4 \text{ ms}^{-1} \text{ to 1 decimal place.}$$

Work out the lower bound for the driving force of the car.

Give your answer correct to 2 decimal places.

..... Newtons
 (3)

24. This graph shows the values of two variables that are in inverse proportion.

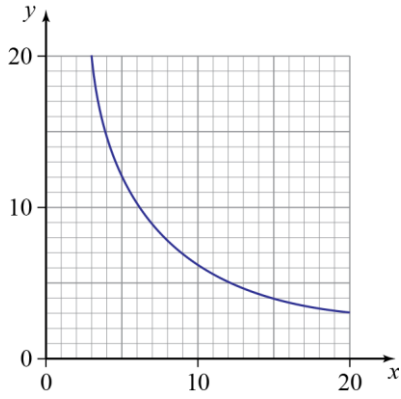

(a) The point $(*, 4)$ lies on the line.

What is the value of $*$?

..... (1)

(b) Work out the formula connecting x and y .

..... (2)

(c) Use the formula to find the value of y when $x = \frac{1}{3}$.

..... (2)

25. Prove that the following shapes are congruent, showing clear reasoning.

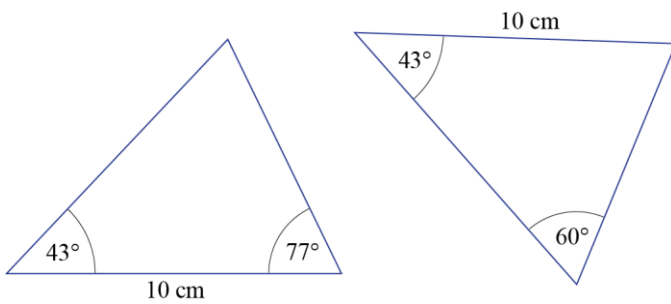

(4)

BLANK PAGE